

R

()

E

A

()

M

S

T

BLACK CHEROKEE
4 - 26 February 2017

What can we say of art that leaves no trace?

That its existence is purported, its absence assured?

Since 1997, Otis Houston, Jr., aka Black Cherokee, has made art on the Franklin D. Roosevelt Drive at 125th Street. Using his body as his primary medium for performance, and working at such a congested crossroads he has found the largest audience for any artist, in some sense larger than the daily droves of all New York City's museums combined.

Though known to many, he remains unknown to most.

Dozens of YouTube videos with thousands of views later, a profile in The New York Times, and a like on Instagram from the art dealer Gavin Brown, this exhibition at ROOM EAST marks the artist's gallery debut. Like Jiri Kovanda's undocumented performances on the streets of Prague in the 1970s, or the peripatetic actions of Fluxus, his peers in performance include Acconci, Burden, Oppenheim, Schneemann, among others. His use of text recalls the blunt force of Kruger, the poetics of Holzer, or at times the bald irony of Ruscha. His sculptures have a similar improvisatory nature of the found object assemblage of Jimmie Durham.

Houston started making collages after taking an art class during his incarceration 1984-1990. The works in the present exhibition were selected from the 1980s and 90s, a highly charged era, during which the tumult of political and corporate powers were channelled through the print media of the time, and consumerism was all ugly sweaters, and padded shoulders. These collages are but a fraction of the work that he has made, and yet they represent the bulk of what is preserved of his artistic output.

In some respects Houston's collages are the progeny of the diametric cultural polarities discussed in Kirk Varnedoe's "High and Low" exhibition at MoMA in 1990. Since the era bookended by the Rodney King riots in Los Angeles in 1992, and the shooting of Amadou Diallo in New York 1999, race and society remain hot button issues, kindling for the resurgent conservative forces of the America that birthed a new mainstream of mistrust.

ROOM EAST
41 Orchard Street
New York, NY 10002

info@roomeast.com
+ 1 212 226 7108
roomeast.com

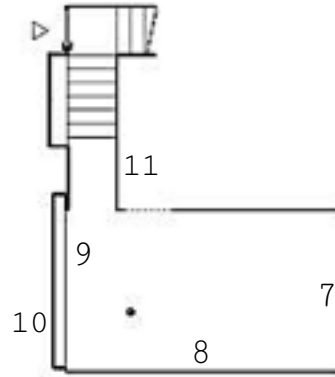
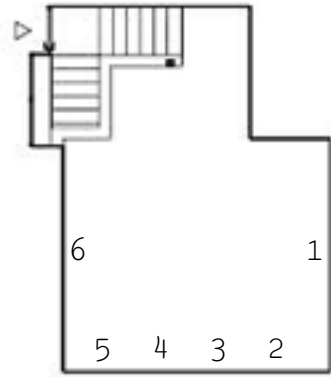

UPSTAIRS

1. Why Not
collage
8.5 x 11 inches
2. Give the people what they want
collages, steel, magnets
48 x 32 inches
3. There was nowhere to go but up
collages, steel, magnets
48 x 32 inches
4. A whole new ballgame
collages, steel, magnets
48 x 32 inches
5. The perfect place to play
collages, steel, magnets
48 x 32 inches
6. Faith Grace
mixed media
dimensions variable

DOWNSTAIRS

7. Ultimately, there's Black.
collages, steel, magnets
48 x 64 inches
8. Police told a lie
mixed media
dimensions variable
9. Color isn't always
collage
8.5 x 11 inches

WINDOW

10. GOOD ARTISTS COPY
GREAT ARTISTS STEAL
towel, spray paint
dimensions variable

OFFICE

11. Indian CLEAN
towel, spray paint
dimensions variable

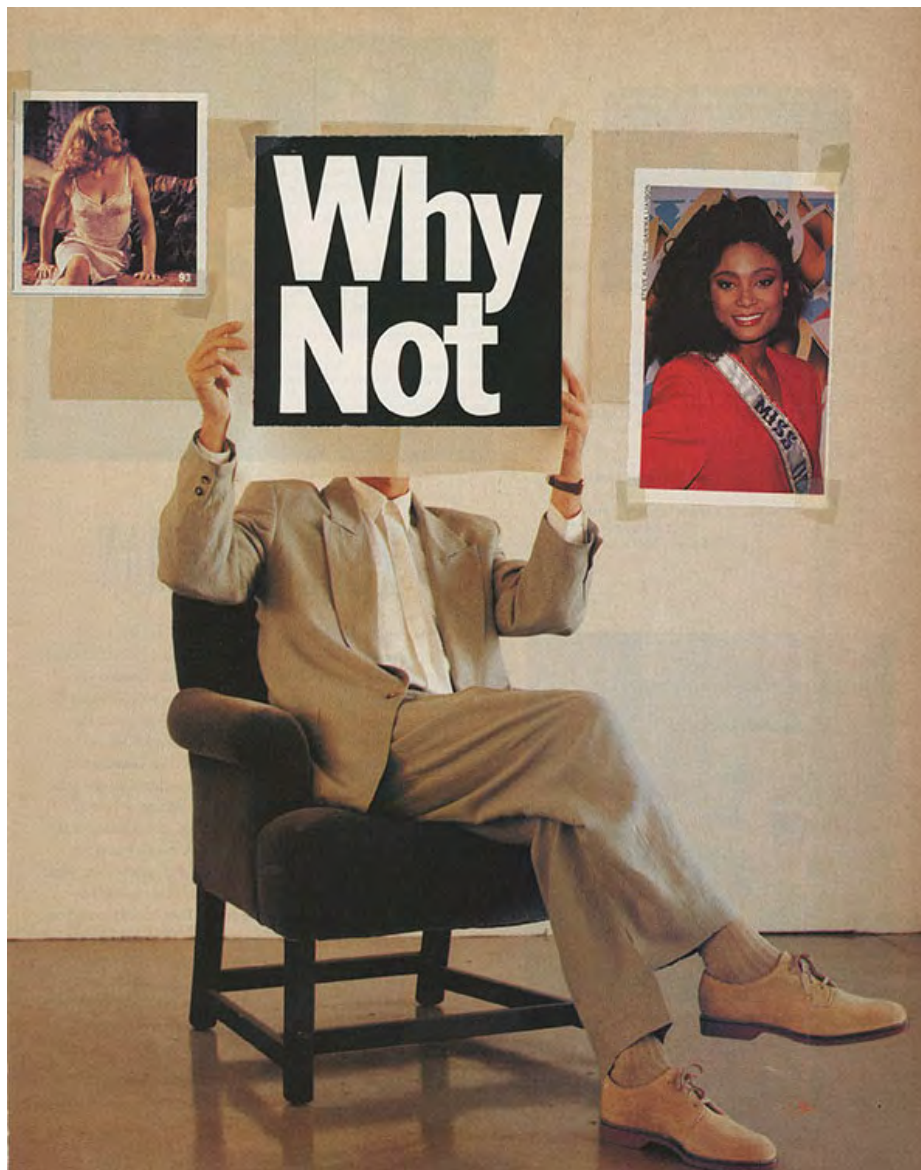

OTIS HOUSTON JR

Why Not

collage

8.5 x 11 inches

OHJ1701

ROOM EAST
41 Orchard Street
New York, NY 10002

info@roomeast.com
+ 1 212 226 7108
roomeast.com



OTIS HOUSTON JR
Give the people what they want
collages, steel, magnets
48 x 32 inches

OHJ1702

ROOM EAST
41 Orchard Street
New York, NY 10002

info@roomeast.com
+ 1 212 226 7108
roomeast.com



OTIS HOUSTON JR
There was nowhere to go but up
collages, steel, magnets
48 x 32 inches

OHJ1703

ROOM EAST
41 Orchard Street
New York, NY 10002

info@roomeast.com
+ 1 212 226 7108
roomeast.com



OTIS HOUSTON JR
A whole new ballgame
collages, steel, magnets
48 x 32 inches

OHJ1704

ROOM EAST
41 Orchard Street
New York, NY 10002

info@roomeast.com
+ 1 212 226 7108
roomeast.com



OTIS HOUSTON JR
The perfect place to play
collages, steel, magnets
48 x 32 inches

OHJ1705

ROOM EAST
41 Orchard Street
New York, NY 10002

info@roomeast.com
+ 1 212 226 7108
roomeast.com



OTIS HOUSTON JR
Faith Grace
mixed media
dimensions variable

OHJ1706

ROOM EAST
41 Orchard Street
New York, NY 10002

info@roomeast.com
+ 1 212 226 7108
roomeast.com



OTIS HOUSTON JR
Ultimately, there's Black.
collages, steel, magnets
48 x 64 inches

OHJ1707

ROOM EAST
41 Orchard Street
New York, NY 10002

info@roomeast.com
+ 1 212 226 7108
roomeast.com



OTIS HOUSTON JR
Police told a lie
mixed media
dimensions variable

OHJ1708

ROOM EAST
41 Orchard Street
New York, NY 10002

info@roomeast.com
+ 1 212 226 7108
roomeast.com

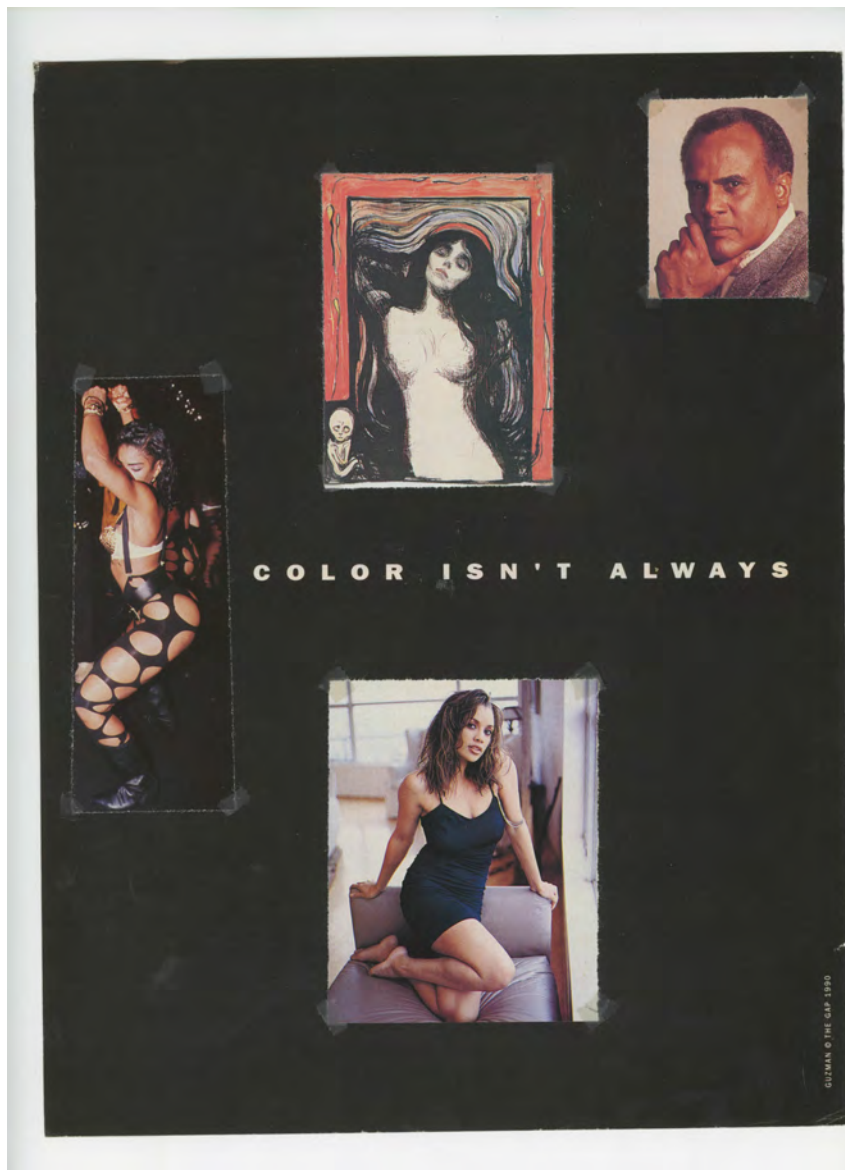

OTIS HOUSTON JR
Color isn't always
collage
8.5 x 11 inches

OHJ1709

ROOM EAST
41 Orchard Street
New York, NY 10002

info@roomeast.com
+ 1 212 226 7108
roomeast.com



OTIS HOUSTON JR
GOOD ARTISTS COPY GREAT ARTISTS STEAL
towel, spray paint
dimensions variable

OHJ1710

ROOM EAST
41 Orchard Street
New York, NY 10002

info@roomeast.com
+ 1 212 226 7108
roomeast.com



OTIS HOUSTON JR
Indian CLEAN
towel, spray paint
dimensions variable

OHJ1711

ROOM EAST
41 Orchard Street
New York, NY 10002

info@roomeast.com
+ 1 212 226 7108
roomeast.com



